

Hermetic Exhaust Gas and Wheel Space Thermocouple and Cable

FOR FRAME 6, 7, AND 9 GAS TURBINE APPLICATIONS

**POWER
& INDUSTRIAL**

THERMOCOUPLE

AMETEK Hermetic Exhaust Gas (EGT) and Wheel Space Frame Turbine Thermocouples are the latest OEM production qualified design and incorporate many improvements over previous thermocouple offerings. AMETEK's new thermocouple is 100% hermetic which ensures longer product life, improved temperature accuracy, and no troublesome insulation resistance failures during operation. The junction box mounts directly to the radiation shield or turbine case and eliminates the problem of mineral insulated cable extending outside the turbine. Materials were carefully selected to ensure long life and to eliminate vibration and galling failures. This new thermocouple, used in conjunction with AMETEK's flexible cable, provides a product that is not only easier to install and maintain, but also a product that is more reliable, accurate, and longer lived.

CABLE

The flexible, stainless steel braided thermocouple Cable mates directly to the new Hermetic Thermocouple and creates a much more reliable thermocouple system than previous designs. The Cable uses Type K wire and terminal lugs so no secondary junction errors are introduced into the thermocouple circuit. The terminal lugs use two different sizes of captivated nuts making it impossible to install incorrectly or to lose any of the hardware.

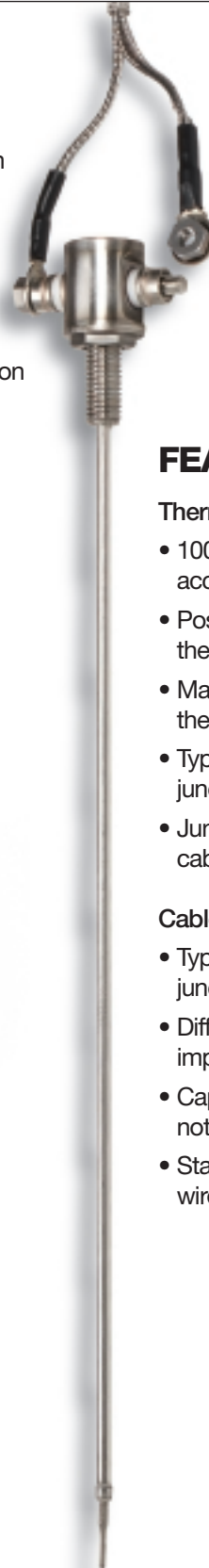

FEATURES AND BENEFITS

Thermocouple

- 100% Hermetic—provides longer life, better accuracy, and no insulation resistance failures
- Positive Stop—ensures proper location of thermocouple tip in radiation shield
- Material Selection—eliminates seizure of thermocouple into radiation shield
- Type K Terminal Studs—reduces secondary junction errors
- Junction Box—simplifies installation and makes cable connection foolproof

Cable

- Type K Terminal Lugs—ensures no secondary junction errors are introduced
- Different Sized Terminal Lugs—make it impossible to cross-wire
- Captivated Hardware—nothing to lose and nothing more to purchase
- Stainless Steel Braid—protects Teflon coated wires from abrasion

AMETEK®

**POWER
INSTRUMENTS**

Experience the Power™

SPECIFICATIONS

Calibration

- Type K, Ungrounded
- Error: Standard ($\pm 0.75\%$) or Special ($\pm 0.4\%$) limits depending on part number

Time Response

- Varies from 1.7 to 4.0 seconds depending on tip configuration

Hermetic Seal

- 1×10^{-6} cc/sec for entire thermocouple

Environment

- -20° to 700° F at thermocouple junction box (-29° to 371° C)
- -20° to 392° F for the cable (-29° to 200° C)
- 100% Humidity for the entire thermocouple

Lengths

- Various from 9" to 123"

Tip Diameters

- Various from 0.062" to 0.125"

Sheath Diameters

- Various from 0.125" to 0.188"

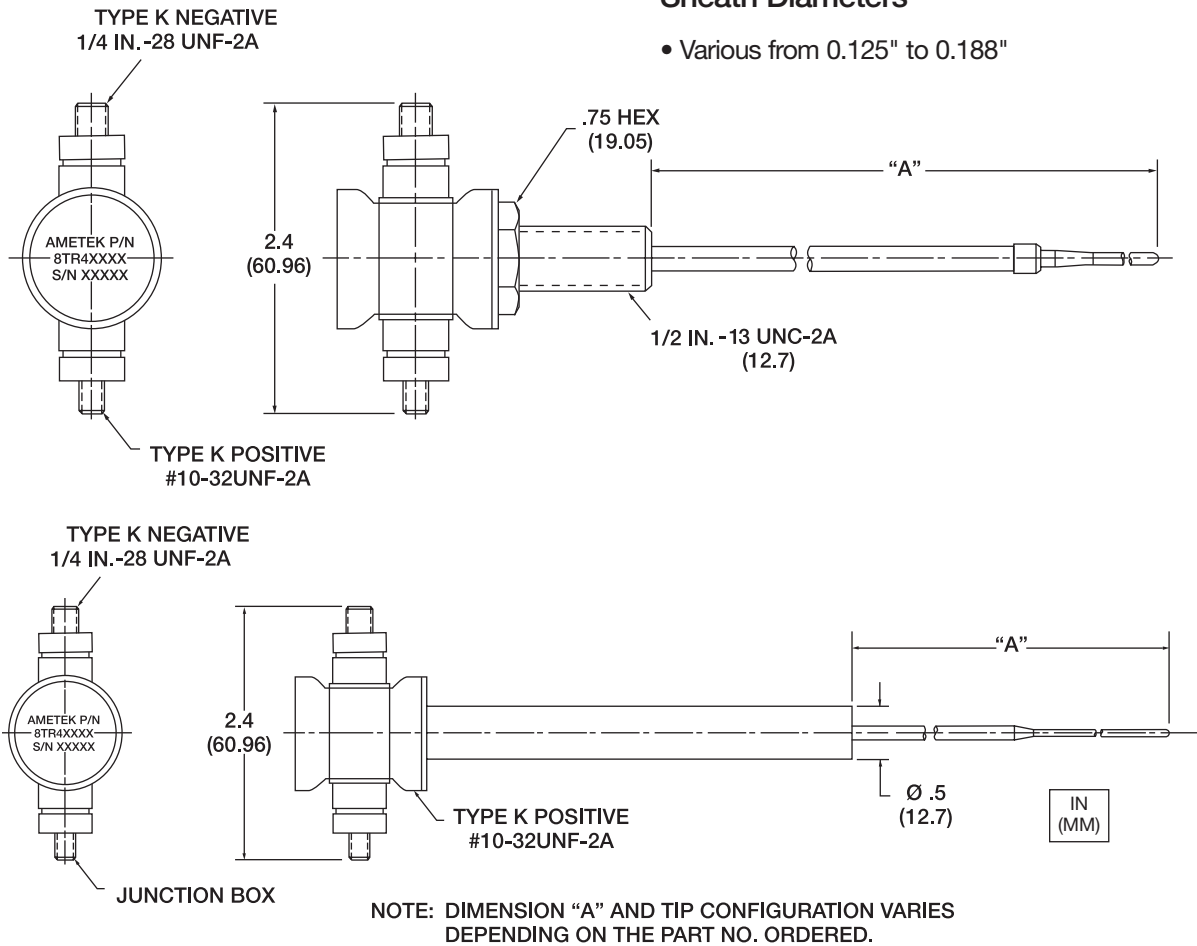

For customer support call:

**AMETEK
POWER INSTRUMENTS**
50 Fordham Road
Wilmington, MA 01887
Tel: 978.988.4903
Fax: 978.988.4990
power.sales@ametek.com

HEADQUARTERS
AMETEK Power Instruments
50 Fordham Road
Wilmington, MA 01887
Tel: 978.988.4903
Fax: 978.988.4990
power.sales@ametek.com

EUROPEAN HEADQUARTERS
Unit 20, Ridgeway
Donibristle Industrial Estate
Dalgety Bay, Dunfermline, KY119JN
Scotland U.K.
Tel: 44.1383.825630
Fax: 44.1383.825715
power.sales@ametek.com

ASIA PACIFIC HEADQUARTERS
10 Ang Mo Kio Street 65
#05-12 Techpoint
Singapore 569059
Tel: 65.6484.2388
Fax: 65.6481.6588



ISO 9001 Certified