



BE1-50/51B with S1 Case and cover

**BE1-50/51B
SELF POWERED
TIME OVERCURRENT
RELAY
RETROFIT KITS**

For non-retrofit applications,
see Product Bulletin UHD.



BE1-50/51B, CO Retrofits



BE1-50/51B, IAC and SFC Retrofits

The BE1-50/51B Time Overcurrent Relay Retrofit kits provide economical, modern replacements for electromechanical overcurrent relays in a variety of applications.

ADVANTAGES

- Self powered from 50/60Hz systems, available for 5 or 1 amp CT secondaries.
- Field selectable curves match original manufacturers' shapes.
- Independent instantaneous overcurrent function.
- Second independent instantaneous available on some models can be applied to reduce arc flash hazard.
- Wired specifically to replace existing electromechanicals.
- Drawout construction, testable in the case.
- Qualified to the requirements of:
- IEEE C37.90-1989, C37.90.1-1989, C37.90.2-1989, UL508
- Patented integrating reset characteristic, even when current goes to zero. Replicates electromechanical reset for all applications.
- Five year warranty.

ADDITIONAL INFORMATION

INSTRUCTION MANUALS

- Request Publication 9252000994 (214, 215, 225 IAC replacement)
- Request Publication 9252000995 (218, 228 IAC replacement with case)
- Request Publication 9252000981 (219, 226 CO replacement)
- Request Publication 9252000790 (240 CO replacement in FT-21 cradle)
- Request Publication 9252000892 (229 SFC replacement)
- Request Publication 9252000894 (230, 234, 239 IAC66K replacement)
- Request Publication 9252000898 (235, 236 CO arc flash upgrade replacement)
- Request Publication 9252000899 (237, 238 IAC arc flash upgrade replacement)

TIMING CURVES

- Request Publication 9252000998 or 9252000894 for Basler-equivalent IAC curves
- Request Publication 9252000999 for Basler-equivalent CO and BS142 curves

STANDARDS, DIMENSIONS and ACCESSORIES

- Request Publication SDA

**FEATURES and
APPLICATION**
Page 2

**FUNCTIONAL
DESCRIPTION**
Pages 3 and 4

SPECIFICATIONS
Pages 5 and 6

**RETROFIT
INFORMATION**
Pages 6 and 7

**ORDERING
INFORMATION**
Page 8

FEATURES

- 15 field selectable, inverse, fixed time and British Standard (BS142) time overcurrent curves on 200 series relays (10 on 100 series).
- Time characteristics extend to 40 X Pickup.
- Instantaneous overcurrent function.
- Wide setting ranges:
 Time Overcurrent: 0.5 to 15.9 (5 Amp Unit)
 0.1 to 3.18 (1 Amp Unit)
 Inst. Overcurrent: 2.0 to 99 (5 Amp Unit)
 0.2 to 19.8 (1 Amp Unit)
 Inst. Overcurrent B: (on equipped models)
 1.0 to 15.9 (5 Amp unit)
 0.2 to 3.18 (1 Amp unit)
- Current pickup accuracy $\pm 2\%$.
- Timing accuracy $\pm 2\%$.
- Continuous automatic calibration.
- Less than 10% transient overreach.
- Zero Pickup setting for safety during installation.
- Timed Overcurrent Reset - Selectable Instantaneous or Decay Characteristic (200 series relays only).
- 5VA burden (at nominal) self powered from 50/60 Hz systems, utilizes standard 5 or 1 Amp CT secondaries.
- Drawout construction.
- Manual method for trip circuit testing.
- Standard magnetically latched targets for TOC and IOC.
- Direct reading front panel controls.
- Positive visual indication that microprocessor is executing code.
- UL recognized under standard 508.
- Qualified to the requirements of:
 -IEEE C37.90.1-1989 for SWC.
 -IEEE C37.90.2-1989 for RFI.
 -IEC 255-5 for impulse.

APPLICATION

The BE1-50/51B is a single phase self powered, micro-processor based time overcurrent relay. The relay is designed for use in applications requiring time delayed coordination for phase or ground overcurrent conditions.

The relay can be used to provide coordinated protection for overhead and underground distribution circuits. Other applications include overcurrent back-up protection for transformers and generators, the protection of neutral grounding resistors and reactors, and motors.

Since all of the time-current characteristics are included within the relay, a standard relay may be ordered before the coordination study is completed, thereby allowing the physical construction to proceed. See Table 1 for available curve types. This is also an advantage as changes in the system configuration or coordination may be accomplished without a hardware change.

All models include memory to replicate the decaying reset of electromechanical relays even when power to the relay is lost. Use this function for applications that require coordination with the resetting of nearby electromechanical relays.

An instantaneous overcurrent element is standard in the relay. This element is designed to minimize transient overreach. The "A" instantaneous element includes selectable delay characteristics for improved coordination with downstream devices and customer requirements. Three instantaneous units are standard with the BE1-50/51B-230, -234, and -239, replacements for the IAC66K motor protection relay. BE1-50/51B models -235 through -238 include a second sensitive instantaneous element for arc flash mitigation applications.

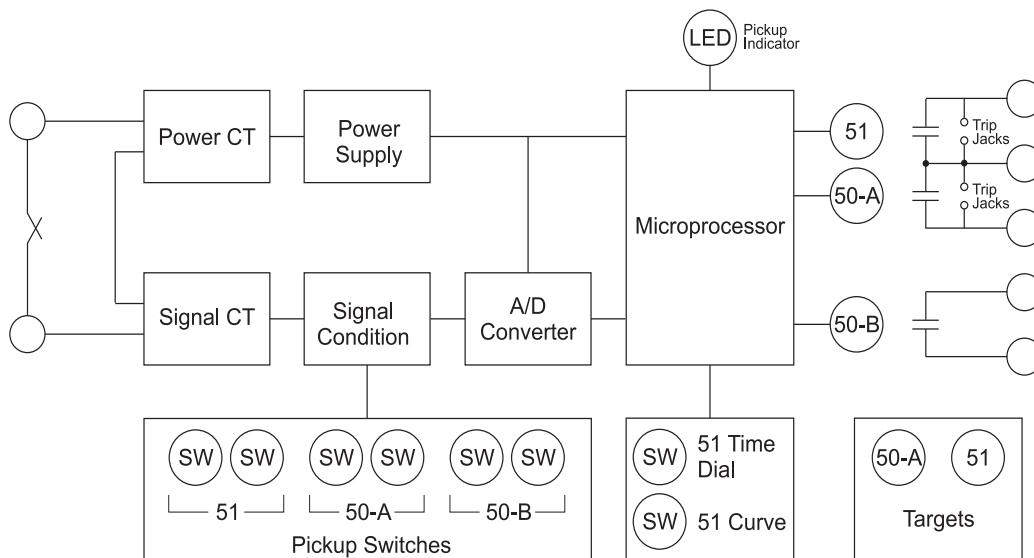

Figure 1 - Functional Block Diagram - Models with 2 Instantaneous

FUNCTIONAL DESCRIPTION

CURRENT INPUT

A single phase of ac current from a 5 Amp, or 1 Amp, 50/60 Hz, system current transformer (CT) is applied to the BE1-50/51B. This input current provides both the power and sensing quantity for the relay.

The current applied to the relay provides the energy for the internal power supply. When sufficient current is available, the Active/Pickup LED will turn green. In applications where circuit loading conditions are less than that required to illuminate the LED, the relay remains operable and will provide overcurrent protection.

MICROPROCESSOR

The setting of the TIME DIAL, TIME CURVE selector switch, and circuit board jumpers provide the micro-processor with ten operating parameters for the desired response by the relay. The microprocessor performs the program operations based on the input current level and internal software program. When the Active/Pickup LED is green, the microprocessor is active and executing code.

The watchdog timer monitors the microprocessor for specific pulses indicating proper program operation. If something occurs to disrupt the microprocessor, these pulses stop, the watchdog timer times out and sends a reset pulse to the microprocessor. The microprocessor resets and resumes normal operation.

TIME ELEMENT CHARACTERISTIC SHAPES FOR CO and BS142 CURVES

All time characteristic curves follow the relation:

$$T_T = \frac{AD}{M^{N-C}} + BD + K = \text{Time to trip}$$

$$T_R = \frac{RD}{M^2-1} = \text{Time for decaying reset}$$

Actual curve constants are available in the Instruction Manual. See page 1 of this bulletin for applicable publication number.

The Active/Pickup LED on the front panel will turn red when the applied current just exceeds the PICKUP setting.

Table 1.

Curve Type		
Basler	Type	Similar To
S1	Short Inverse	ABB CO-2
S2	Short Inverse	GE-IAC-55
L1	Long Inverse	ABB CO-5
L2	Long Inverse	GE IAC-66
D1, D2	Definite Inverse	ABB CO-6
M1, M2	Definite Inverse	ABB CO-7
I1	Inverse	ABB CO-8
I2	Inverse	GE IAC-51
V1	Very Inverse	ABB CO-9
V2	Very Inverse	GE IAC53
E1	Extremely Inverse	ABB CO-11
E2	Extremely Inverse	GE IAC 77
B	British Standard	BS 142-B
	Very Inverse	
C	British Standard Extremely Inverse	BS 142-C
F	Fixed Time	none

Table 2. Current Sensing Capabilities

50/60 Hz System CT Secondary	Time Element Pickup Range	Time Element Max. Continuous Current	Time Element Max. Current For 1 Second	Instantaneous Pickup Range	Time Element Pickup Accuracy	Instantaneous Pickup Accuracy
5 Amp models	0.5 to 15.9 Amps in 0.1 Amp steps	14 Amps	400 Amps	A: 2 to 99 Amps in 1 Amp Steps B: 1 to 15.9 Amps in 0.1 Amp Steps	2% from 0.5 to 15.9 Amps	2% from 1 to 99 Amps
1 Amp models	0.1 to 3.18 Amps in .02 Amp steps	2.8 Amps	80 Amps	A: 0.4 to 19.8 Amps in 0.2 Amp Steps B: 0.2 to 3.18 Amps in 0.02 Amp Steps	2% from 0.1 to 3.18 Amps	2% from 0.2 to 19.8 Amps

RESET

Reset occurs when the current level is less than pickup. Internal switch provides selection of either an Instantaneous or a decaying reset characteristic.

The instantaneous reset characteristic forces the timer to zero when the input current falls below 95% of setting. This

fast reset characteristic prevents the ratcheting effect on electromechanical relay disks that occurs for repeated faults.

The decaying reset characteristic replicates the decaying reset of electromechanical relay disks. When enabled, the relay will continue the decaying process even when the input current goes to zero.

FUNCTIONAL DESCRIPTION, continued

INSTANTANEOUS ELEMENT CHARACTERISTICS

The characteristic for phase faults is faster because the relay will be powered-up. However, the tripping characteristic for ground applications is slightly longer to allow time to power-up the relay. This longer trip time for ground applications is beneficial because it helps avoid nuisance trips. These timing characteristics are shown in Figure 2.

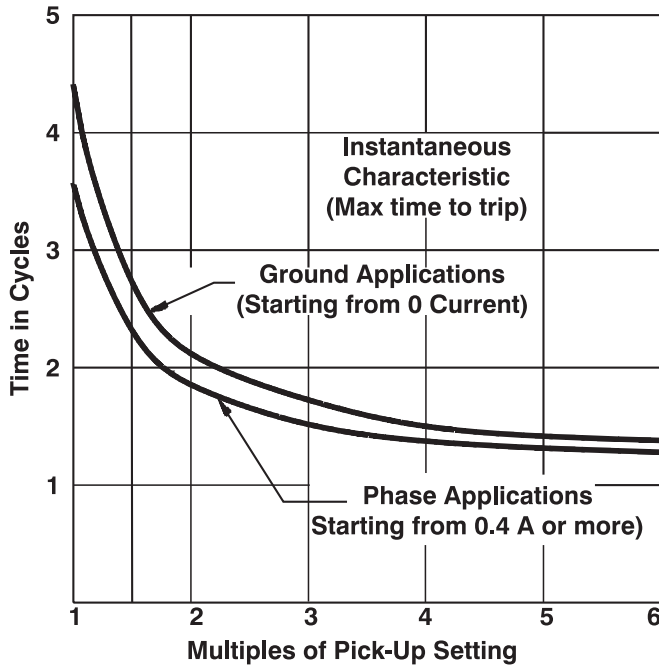

Figure 2 - Instantaneous Characteristics

Additional definite time delay of 0.1 seconds may be added to the first instantaneous element. The definite delay is determined by SW3-2 on the circuit card.

OUTPUTS

Separate output contacts are provided for the TIME (51), INST A, and INST B. All output contacts are configured normally open (NO).

MANUAL TRIP TESTING

The relay is provided with front panel test points to allow shorting the output terminals to verify external control circuit wiring.

TARGETS

Two target indicators are provided as a standard feature of the BE1-50/51B. These magnetically latched, current operated targets provide visual indication of trip by the TIME or INST output contact. These targets must be manually reset after the abnormal condition has been removed or corrected.

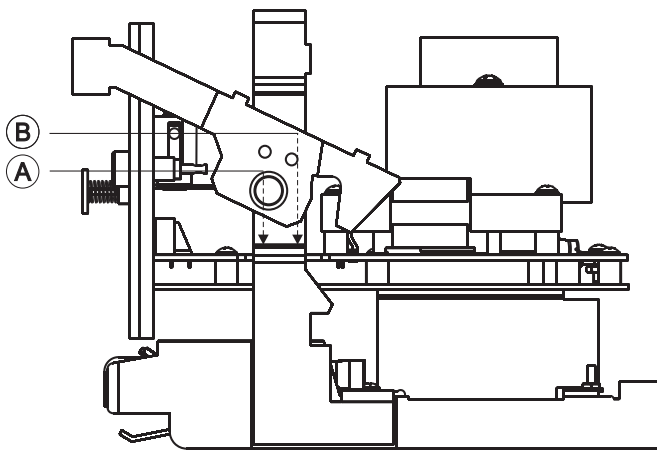

237
A: Units
B: Tenths

238
A: Amps x 0.2
B: Amps x 0.02

Figure 3 - Side View, 50-B adjustments, BE1-50/51B-237 and -238

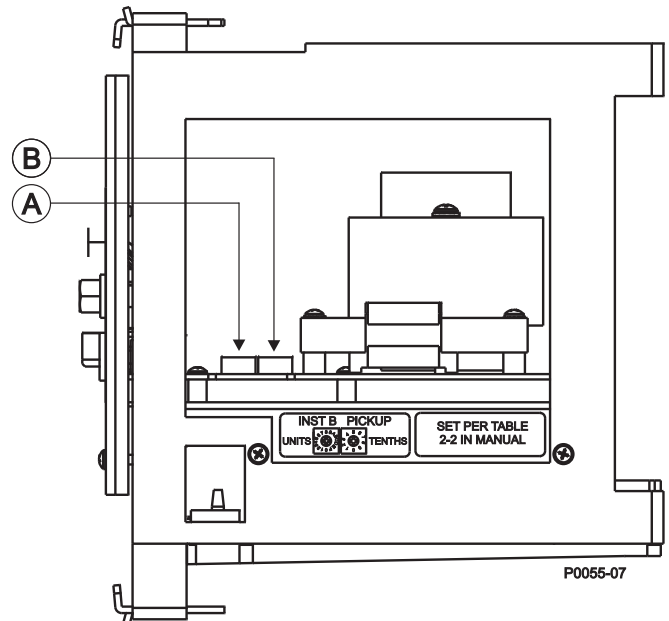

230, 235
A: Units
B: Tenths

234, 236
A: Amps x 0.2
B: Amps x 0.02

Figure 4 - Side View, 50-B Adjustments, BE1-50/51B-230, -234, -235, -236, and -239

SPECIFICATIONS

CURRENT SENSING INPUT:	Continuous Current	One Second Current
5 Amp Unit	14.0 Amps	400 Amps
1 Amp Unit	2.8 Amps	80 Amps

TIME PICKUP RANGE:

5 Amp Unit: 0.5 to 15.9 Amps in 0.1 Amp steps
1 Amp Unit: 0.1 to 3.18 Amps in 0.02 Amp steps

TIME DROPOUT:

Not less than 95% of pickup value.

TIME PICKUP ACCURACY:

± 2% of setting

TIME DIAL RANGE:

0.0 to 9.9 in 0.1 steps

TIME CHARACTERISTICS:

Nine inverse time and 1 fixed time function can be selected by a front panel switch. Characteristic curves are defined by the time characteristic equation. The fixed time characteristic provides delays of 0.0 to 9.9 seconds corresponding to the dial setting.

INVERSE TIMING ACCURACY:

± 2%, ±1 cycle for multiples of pickup from 2 to 40. Below multiples of 2, errors may increase directly proportional to the value of $\frac{1}{(M^N-1)}$.

FIXED TIME ACCURACY:

±2% or 30 milliseconds, whichever is greater.

TIME RESET:

Instantaneous or decay, internally selectable.

INST PICKUP RANGE:

5 Amp Unit: 2.0 to 99 Amps in 1 Amp steps
1 Amp Unit: 0.2 to 19.8 Amps in 0.2 Amp steps

INST B PICKUP RANGE

BE1-50/51B-230, -235, -237, -239 (5 Amp Unit):

1.0 to 15.9 Amps in 0.1 Amp steps

BE1-50/51B-234, -236, -238 (1 Amp Unit):

1 Amp Unit: 0.2 to 3.18 Amps in 0.02 Amp steps

INST DROPOUT:

95% of pickup

INST PICKUP ACCURACY:

± 2% of setting

INST CHARACTERISTIC:

See Figure 2. Additional user selectable (by DIP switches) definite delay of 0.1 seconds.

INST TRANSIENT RESPONSE:

Less than 10% overreach with system time constants up to 40 milliseconds.

BURDEN: Burden is non-linear and resistive.

5 Amp Unit: 4.8 Ohms @ 0.5A & 0.2 Ohms @ 5A
1 Amp Unit: 120 Ohms @ 0.1A & 5 Ohms @ 1A

TARGETS:

Magnetically latched, manually reset for TIME and INST output functions.

Operate Current: 0.2 Amp minimum

Coil Resistance: 0.1 Ohm

Operate Time: < 1 millisecond

TARGET OPERATE CURRENT:

Units with second instantaneous include jumper-selectable target operate currents.

Units without jumpers: 80-200 mA

Units with Jumper 1-2: 0.9-2.25 A

Units with Jumper 2-3: 80-200 mA

OUTPUTS: (50/51)

Resistive:

120/240 Vac: Make and carry 30 Amp for 0.2 sec., carry 7 Amp for 2 min., 3 Amp continuously, and break 5 Amp.

125/250 Vdc: Make and carry 30 Amp for 0.2 sec., carry 7 Amp for 2 min., 3 Amp continuously, and break 0.3 Amp.

Inductive:

120/240Vac, 125/250Vdc: Make and carry 30 Amp for 0.2 sec., carry 7 Amp for 2 min., 3 Amp continuously, and break 0.3 Amp. (L/R=0.04).

ISOLATION:

2000 Vac at 50/60 Hz for one minute (1500 Vac for one minute across open contacts) in accordance with IEC 255-5 and IEEE C37.90-1-1989 (Dielectric Test).

SURGE WITHSTAND CAPABILITY:

Qualified to IEEE C37.90.1-1989

FAST TRANSIENT:

Qualified to IEEE C37.90.1-1989

IMPULSE TEST:

Qualified to IEC 255-5

RADIO FREQUENCY INTERFERENCE (RFI):

Qualified to IEEE C37.90.2-1989. Field tested using five watt transceiver operating at random frequencies centered around 144 MHz and 440 MHz.

TEMPERATURE:

Operating Range -40° C (-40° F) to 70° C (158° F).

Recommended Storage Range -50° C (-58° F) to 70° C (158° F).

SHOCK:

15g in each of three mutually perpendicular planes.

SPECIFICATIONS, continued

VIBRATION:

2g in each of three mutually perpendicular planes swept over the range of 10 to 500 Hz for a total of 6 sweeps, 15 minutes per sweep.

AGENCY:

cURus recognition per UL Standard 508, File E97035 and CSA Standard C22.2 No. 14

CASE SIZE: S1 (-218 and -228 only)

NET WEIGHT: 6.1 pounds
8.6 pounds (-218 and -228 only)
4.3 pounds (-240 only)

RETROFIT FEATURES



BE1-50/51B CO Retrofit Cradle and cover

The BE1-50/51B-219, -226, -235, and -236 retrofit kits consist of a cradle and a cover and provides for installing a Basler BE1-50/51B single-phase time overcurrent relay in an existing CO case without making any wiring changes.

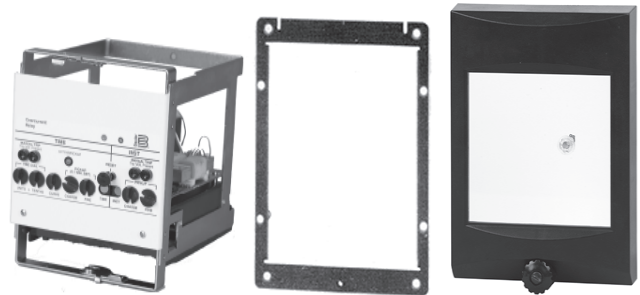

BE1-50/51B IAC Retrofit Cradle, adapter plate and cover

The BE1-50/51B-214, -215, -225, -230, -234, -237, and -238 retrofit kits consist of a cradle, an adapter plate, and a cover and provides for installing a Basler BE1-50/51B single-phase time overcurrent relay in an existing IAC case without making any wiring changes.

The BE1-50/51B-229 retrofit kit (not shown) provides for installation of a Basler BE1-50/51B single-phase time overcurrent relay in an existing SFC case without wiring changes. The BE1-50/51B-229 offers the same functionality, outputs, and curves as the 50/51B-214 but is designed to be an exact replacement for the SFC.

The BE1-50/51B-218 and -228 (not shown) are complete IAC replacement relays, including case.

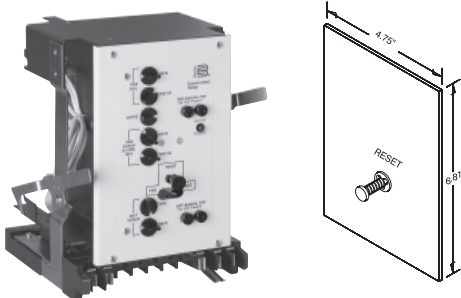

BE1-50/51B-240 CO Retrofit Cradle and replacement glass

The BE1-50/51B-240 retrofit kit consists of a cradle and a piece of replacement Plexiglass and provides for installing a Basler BE1-50/51B-240 relay in an existing CO FT-21 case.

ELECTROMECHANICAL REPLACEABLE MODELS

- The 240 is a direct replacement for a CO relay in an FT-21 case.
- The 219 or 226 kit is a direct replacement for a CO drawout relay in an FT-11 case.
- The 214 or 225 kit is a direct replacement for an IAC drawout relay.
- The 229 is a direct replacement for selected SFC drawout relays.*
- The 230, 234, and 239 are direct replacements for the IAC66K motor protection relay.
- The 215 is a replacement for the IAC66C relay, except Terminals 1 and 9 are internally connected.
- The 235 or 236 kit is a direct replacement for a CO drawout relay in an FT-11 case. It has an additional low-set instantaneous to help reduce arc flash hazard.
- The 237 or 238 kit is a direct replacement for an IAC drawout relay with an additional low-set instantaneous to help reduce arc flash hazard.
- No electrical or mechanical rework is required to panels during retrofit.
- Competitively priced.
- One model replaces more than 100 IAC or 40 CO models in an FT-11 case listed on next page.
- Patent #5,751,532.
- Numerous technical advantages:
 - All units are equipped with an instantaneous element.
 - Instantaneous element can be set lower, because the relay is corrected for transient overreach. Therefore, the range does not need to be as high as on the IAC relay.
 - Ten selectable curves and wide pickup ranges.
 - Lower burden extends linear range of CTs.
 - Self-calibration feature eliminates need for recalibration, thereby reducing maintenance labor.

CO models that may be retrofitted with the BE1-50/51B:

Curve	CO Model Numbers
Short Time	CO-2*11*1N
Long Time	CO-5*11*1N
Definite	CO-6*11*1N
Moderately Inverse	CO7*11*1N
Inverse	CO-8*11*1N
Very Inverse	CO-9*11*1N
Extremely Inverse	CO-11*11*1N

IAC models that may be retrofitted with the BE1-50/51B:

Curve	IAC Model Numbers
Inverse	12IAC51A***A
	12IAC51B***A
Very Inverse	12IAC53A***A
	12IAC53B***A
Extremely Inverse	12IAC77A***A
	12IAC77B***A
Short Time	12IAC55A***A
	12IAC55B***A
Long Time	12IAC66A**A
	12IAC66B**A
	12IAC66C**A

NOTES:

- * = any digit covering all pickup ranges, instantaneous, non-instantaneous, and 50 Hz and 60 Hz models.
- Units with instantaneous elements are designated with a "B" for the eighth character in the model number.

SFC models that may be retrofitted with the BE1-50/51B-229:

Curve	SFC Model Numbers
Inverse	12SFC151**A
Very Inverse	12SFC153**A
Extremely Inverse	12SFC177**A

NOTE: The -229 is based on and offers the same functionality as the -214 IAC replacement. Available curves and outputs (one 50 and one 51 contact) are identical to the BE1-50/51B-214.

IAC models that may be retrofitted with the BE1-50/51B-230 and -234:

Curve	IAC Model Number
Long Time	12IAC66K

ORDERING

MODEL NUMBER: BE1-50/51B Time Overcurrent Relay

HOW to Order: Designate the Model Number and the three-digit number from Table 3 to define the configuration desired.

Table 3.

RETROFIT RELAY PACKAGES	Number of Instantaneous Elements	MODEL NUMBER*
For 5 Amp System CT Secondaries Retrofit kit for IAC relays Cradle plugs into existing case. Adapter plate and new cover included.	1	BE1-50/51B-214 BE1-50/51B-215
Complete IAC replacement relay with same terminal connections as IAC units. S1 style case.	1	BE1-50/51B-218
Retrofit kit for IAC relays Cradle plugs into existing case. Adapter plate, connection plug and new cover included.	2	BE1-50/51B-237
Retrofit kit for IAC66K relay Cradle plugs into existing case. Adapter plate, connection plug and new cover included.	2	BE1-50/51B-230
Retrofit kit for CO relays (FT-21 case). Replacement glass for existing cover is included. Cradle plugs into existing case.	1	BE1-50/51B-240
Complete IAC66K replacement relay with same terminal connections as IAC66K units. S1 style case with cover.	2	BE1-50/51B-239
Retrofit kit for CO relays. Cradle plugs into existing case. A new cover included.	1	BE1-50/51B-219
Retrofit kit for CO relays Cradle plugs into existing case. New cover included.	2	BE1-50/51B-235
Retrofit kit for SFC relays Cradle plugs into existing case. Adapter plate and new cover included.	1	BE1-50/51B-229**
For 1 Amp System CT Secondaries Retrofit kit for IAC relays Cradle plugs into existing case. Adapter plate and new cover included.	1	BE1-50/51B-225
Complete IAC replacement relay with same terminal connections as IAC units. S1 style case.	1	BE1-50/51B-228
Retrofit kit for IAC relays Cradle plugs into existing case. Adapter plate, connection plug and new cover included.	2	BE1-50/51B-238
Retrofit kit for IAC66K relay Cradle plugs into existing case. Adapter plate, connection plug and new cover included.	2	BE1-50/51B-234
Retrofit kit for CO relays Cradle plugs into existing case. New cover included.	2	BE1-50/51B-236
Retrofit kit for CO relays Cradle plugs into existing case. New cover included.	1	BE1-50/51B-226

** See notes on page 7 for SFC compatibility information.

STANDARD ACCESSORY: A test plug (Basler P/N 10095) is available to allow testing of the relay without removing external wiring.



Basler Electric



PA.E. Les Pins, 67319 Wasselonne Cedex FRANCE
 Tel +33 3.88.87.1010 Fax +33 3.88.87.0808
 e-mail: beifrance@basler.com

Route 143, Box 269, Highland, Illinois U.S.A. 62249
 Tel +1 618.654.2341 Fax +1 618.654.2351
 e-mail: info@basler.com

No. 59 Heshun Road Loufeng District (N),
 Suzhou Industrial Park, 215122, Suzhou, P.R.China
 Tel +86(0)512 6346 1730 Fax +86(0)512 8227 2888
 e-mail: beichina@basler.com